

Clackamas In-Swing & Out-Swing Doors

The Clackamas series swing door offers builders and architects an attractive solution for both residential and commercial markets. Incorporating the latest developments and performance enhancements of the European hardware features including the multi-point locking system resulting in an incredibly secure and structurally sound door.

This series is available in white, sandstone, and clay on which can be laminated with a high-performance film for color fastness and durability.

Features:

- Frame Depth: 3-1/4"
- Up to 1-5/8" glazing capability for increased energy efficiency and acoustical performance.
- Reinforced Frame & Sash this allows for our product line to be designed into plans for taller buildings and commercial applications.
- Elegant, sculpted sash design can be used in many door applications.
- ADA sill available

Clackamas at a glance performance:

- Structural: up to LC PG50
- Acoustical: Currently no STC testing
- Thermal: down to 0.17*

**based on simulation*

Due to continual product R&D these details listed are subject to change at anytime. NFRC data based on using triple silver LowE coatings.

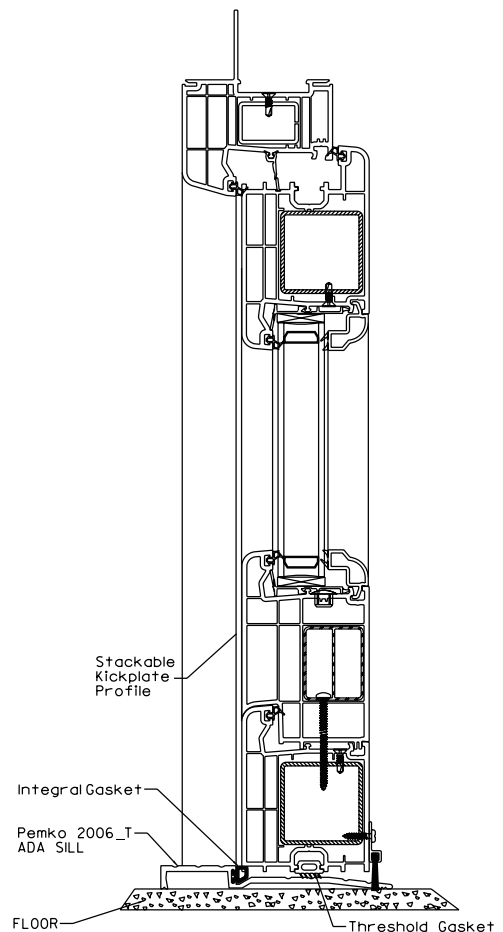

Window Types Key

FW - Fixed Window no Sash
 FS - Fixed Window with Sash
 CS - Casement Window
 AW - Awning Window

SH - Single Hung Window
 SL - Sliding Window
 SD - Swing Door
 PD - Sliding Patio Door
 VT - VTAC